

## Mounting Plates

for Adjustable Slide Units GN 900, Aluminum

### SPECIFICATION

#### Types

- Type **A**: Without retaining bores
- Type **B**: With retaining bores for rotary tables

Aluminum

Anodized, natural color

Socket cap screws DIN 912

Stainless steel

### INFORMATION

Mounting plates GN 900.4 type A are used for installing fixtures on the operator's side. Type B is used for installing a rotary table GN 900.6 (see page 677).

The mounting plate can be simply clamped on to the slide and no additional drilled holes are required.

The small fixing plates serves as an additional fine adjustment of the mounting plate with the adjustable slide unit.

All parts required to make up a set are included.

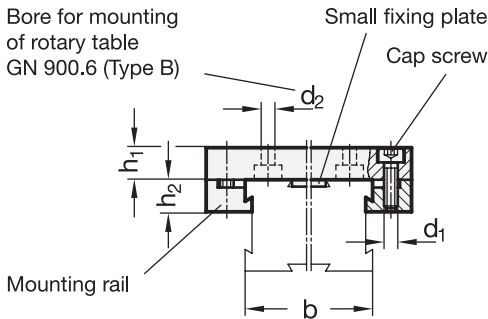

### Mounting example

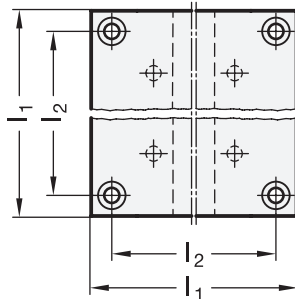
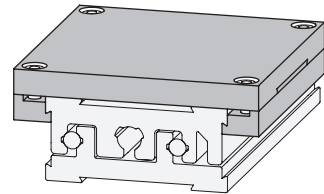

### GN 900.4

Description	b Size of the slide	l <sub>1</sub>	d <sub>1</sub>	d <sub>2</sub>	h <sub>1</sub>	h <sub>2</sub>	l <sub>2</sub>	For rotary tables	⚖
GN 900.4-30-41-A	30	41	M 2.5	-	5	4.2	35.4	-	29
GN 900.4-50-67-A	50	67	M 3	-	8	7	58	-	120
GN 900.4-80-105-A	80	105	M 4	-	12	12.5	92	-	441
GN 900.4-120-145-A	120	145	M 5	-	16	13.8	131.8	-	1100
GN 900.4-50-67-B	50	67	M 3	5.5	8	7	58	GN 900.6-55	125
GN 900.4-80-105-B	80	105	M 4	5.5	12	12.5	92	GN 900.6-80	430
GN 900.4-120-145-B	120	145	M 5	5.5	16	13.8	131.8	GN 900.6-80	1055